

Description of Map Units

QUATERNARY SYSTEM

HOLOCENE

- Ha** Alluvium—Undifferentiated deposits of small upland streams; alluvial deposits of minor streams and creeks of varying textures, filling valleys incised into older deposits.
- Hb** Backswamp deposits—Fine-grained Holocene deposits of rivers, underlying the flood basins between meander belts.
- Hrl** Red River natural levee deposits—deposits forming low natural levees flanking the meander belts of the Red River.

QUATERNARY UNDIFFERENTIATED

- Qaf** Quaternary alluvial-fan deposits—unnamed alluvial-fan deposits.

PLEISTOCENE

DEWEYVILLE ALLOGROUP

- Pd** Deweyville Allogroup, undifferentiated—alluvial deposits of ancestral late Pleistocene coastal plain streams and certain Mississippi River tributaries including the Red, Ouachita, Sabine, Calcasieu, Pearl, and Bogue Chitto valleys. Multiple levels are locally recognized.

PRAIRIE ALLOGROUP

- Pp** Prairie Allogroup, undifferentiated—a diverse depositional sequence of late to middle Pleistocene deposits of the Mississippi River, its tributaries, and coastal plain streams; includes terraced fluvial (meander belt, backswamp, and braided stream), colluvial, estuarine, deltaic, and marine units deposited over a considerable interval (Wisconsin to Sangamon) of the late Pleistocene. Multiple levels are recognized along alluvial valleys and coast-parallel trends, and are grouped into two principal temporal phases. The allogroup is undifferentiated where local fluvial terrace remnants flank the more headward portions of stream bottoms.

- Ppl** Upper Prairie Allogroup—Late Pleistocene alluvial deposits of the younger of the Prairie Allogroup temporal phases of the Red River valley. Where observed in the area northwest of Shreveport, the unit consists of grayish clayey very fine sand, with red mottles in places, weathering yellowish to yellowish brown.

INTERMEDIATE ALLOGROUP

- Pib** Montgomery alloformation—meander belt deposits of the Red River in central Louisiana. The unit is blanketed by yellow loam, incises the Bentley alloformation and older units, and is incised by Prairie Allogroup and Holocene units.

TERTIARY SYSTEM

MIOCENE

FLEMING GROUP

- Mfw** Williamson Creek Formation, Fleming Group—very fine to very coarse sand, averaging very fine to medium overall, with overall poor sorting. Overall grain size appears coarser than in other Fleming subunits, with sands containing much more of the coarser size fractions and a larger proportion of quartz granules in places. Granules are extremely abundant locally and consist almost exclusively of quartz, in places comprising sandy granule conglomerate. Internal features include medium-scale trough cross beds in coarser, granule-rich sand and sandy granule conglomerate, with bedding sets fining upward in places. Characteristics of the surface Williamson Creek accord generally with continental, fluvial-dominated deposition.

- Mfcb** Carnahan Bayou Formation, Fleming Group—texturally heterogeneous suite of generally poorly sorted sediments comprising varying admixtures of sand/sandstone, with granules in places; silt/siltstone; and clay/mud. Primarily clayey very fine to fine sand containing some coarse and very coarse sand with some granules. Granules and pebbles include both quartz and rock fragments, with granules comprising predominantly quartz, and pebbles and cobbles consisting mostly of rock fragments; the rock fragments comprise both lightish clay/mud rip-up clasts, and in places, dark or black chert. Includes petrified wood and thin tuffaceous beds locally. Characteristics of the surface Carnahan Bayou accord generally with continental, fluvial-dominated deposition, with the large proportion of silt observed in places suggestive of the onset of transition to deltaic facies. In eastern Texas the Carnahan Bayou is classified as the uppermost portion of the Cathoula Formation.

Open Water, Inundated Area, Swamp

Contact—includes inferred contacts.

Streams

Topographic Contours

Produced and published by the Louisiana Geological Survey
3079 Energy, Coast & Environment Building, Louisiana State University
Baton Rouge, LA 70803 • 225/578-5320 • www.lsu.edu/lgs/

Production of this map was supported by the U.S. Geological Survey,
Department of the Interior, under Assistance Award No. 02HQAG0035.

Copyright ©2003 and 2023 by the Louisiana Geological Survey

Geology: Richard P. McCulloh and Paul Heinrich

GIS compilation: R. Hampton Peele, Anuradha Eragani, Prammagnaanam
Vijaiamath, P. Lakshmi Deepti, and Kalyani Tavisala

Revision GIS/Cartography: Robert L. Paulsell

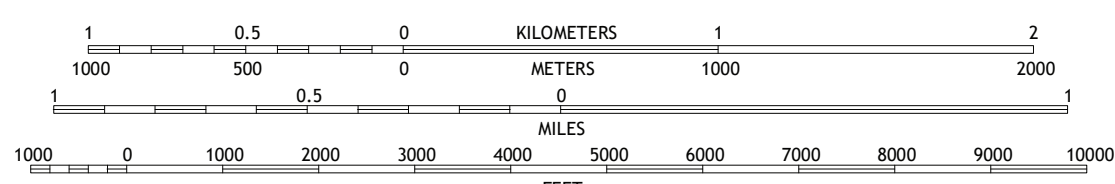
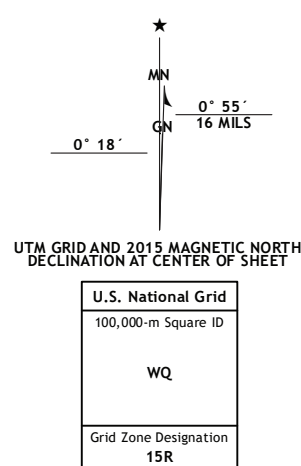

SCALE 1:24,000
CONTOUR INTERVAL 10 FEET
NORTH AMERICAN DATUM OF 1983 (NAD 83)
WORLD GEODETIC SYSTEM 1984 (WGS 84)
UNIVERSAL TRANSVERSE MERCATOR PROJECTION, ZONE 15
NORTH AMERICAN VERTICAL DATUM OF 1988

1	2	3
4	5	6
7	8	Libuse

ADJOINING QUADRANGLES



ROAD CLASSIFICATION	
Expressway	Local Connector
Secondary Hwy	Local Road
Ramp	4WD
Interstate Route	US Route
	State Route

This research is supported by the U. S. Geological Survey, National
Cooperative Geologic Mapping Program. The views and conclusions
contained in this document are those of the authors and should not be
interpreted as necessarily representing the official policies, either expressed
or implied, of the U. S. Government or the state of Louisiana. This map
was produced to conform with the National Geospatial Program US Topo
Product Standard, 2011.

This map has been carefully prepared from the best existing sources
available at the time of preparation. However, the Louisiana Geological
Survey and Louisiana State University do not assume responsibility or
liability for any reliance thereon. This information is provided with the
understanding that it is not guaranteed to be correct or complete, and
conclusions drawn from such data are the sole responsibility of the user.
These geologic quadrangles are intended for use at the scale of 1:24,000.
A detailed on-the-ground survey and analysis of a specific site may differ
from these maps.

Geologic Map of the Ball 7.5 minute quadrangle
Rapides and Grant Parishes Louisiana

Roads	U.S. Census Bureau, 2017
Roads within US Forest Service Lands	FS Topo Data
Names	GNIS, 1980 - 2017
Hydrography	National Hydrography Dataset, 2002 - 2017
Contours	National Elevation Dataset, 2008 - 2011
Boundaries	Multiple sources; see metadata file 2017
Wetlands	FWS National Wetlands Inventory 1974